



Model No. LFHW40102

Large security chest



Best Used For:



Fire



Flood

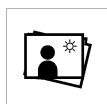

Pictures

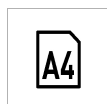

A4 Paper Documents



Small Electronics



Storage Devices, USB Flash Drives

Overview & Features

Product Features

- Fire and water resistant construction
- UL/ETL verified 30 minutes fire protection for documents, official papers, as well as digital items (CD, USB sticks) up to 843°C
- ETL verified for water submersion to protect documents and other valuable items from flood damage
- Key lock - includes 2 keys
- Privacy key lock keeps documents and valuables away from prying eyes and prevents the lid from opening in the event of a fire
- Fits A4 documents
- Integrated LED lid light facilitates the access to the content

Certifications



Product Details

The Master Lock No. LFHW40102 Large Security Chest protects your family's most important paper (fits A4 paper size), media, and valuables from fire and flood damage. The interior LED lighting makes the access to the content easy, even in dark spaces.

Product Specifications

Product Number	LFHW40102
Description	Retail Boxed Packaging
Master Carton Qty	1
Exterior dimensions (H x W x D)	35,9cm x 42,1cm x 35,1cm
Interior dimensions (H x W x D)	29,5cm x 30,5cm x 20,6cm
Interior Volume	18,5L
Weight W/o Packaging	18,6kg
Colour	Charcoal Grey
Batteries	Requires 2 CR 2032 batteries (included)

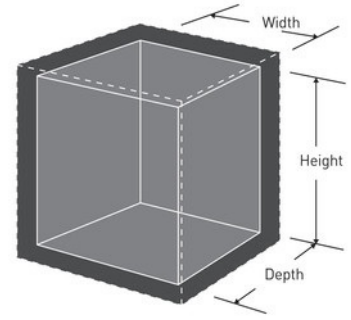

Master Lock Europe S.A.S.

131, avenue Charles de Gaulle - 92200 Neuilly sur Seine - France
O:+33-1-41437200 | F:+33-1-41437204
www.masterlock.eu